



# CleanSwitch

Contact-free switch for convenient activation of entrances  
with strict hygiene and design requirements

## Hygienic, attractive, integrable

- Contact-free, hygienic door opening
- Attractive design with visual feedback
- Compatible with standard flush-mounted boxes



reddot design award  
winner 2018

# CleanSwitch

## Contact-free switch for convenient activation

### Hygienic in every application

Any place in which groups of people are found can be a breeding ground for germs and other pathogens. Contact surfaces – and in particular, door handles – are responsible for spreading vast amounts of bacteria and viruses, some of which can pose a real risk to health. This becomes critical when it affects healthcare facilities. Strict hygiene standards are also imposed in the catering industry, as well as other fields in which food is prepared.

CleanSwitch provides a contact-free, hygienic method of opening doors. It works by means of a deliberate hand gesture within the detection range of 10 to 60 centimetres – helping to stop germs in their tracks. Thanks to its attractive design featuring coloured LED feedback, CleanSwitch is an appealing, user-friendly addition to its environment. It takes just a few minutes to get the activation switch up and running and installation can be carried out in any standard flush-mounted box. The highly durable front can be treated using standard surface disinfectants in hospital areas. To ensure that it can be used without any problems in particularly moist or wet environments, CleanSwitch offers reliable protection that meets IP65.



## Benefits for you

### Hygiene

CleanSwitch has been specifically developed for use in buildings subject to strict hygiene requirements, such as healthcare facilities, sanitary areas and the catering industry. It activates entrance points using a contact-free method – a deliberate gesture made by the user – and otherwise keeps doors closed. This helps to prevent the spread of germs. CleanSwitch can also be treated with any standard cleaning agent or disinfectant.

### Easy installation

The intelligent way in which the system has been designed ensures it is compatible with all standard flush-mounted boxes. CleanSwitch is extremely quick and easy to install. Set-up of the device is an intuitive process that requires no tools – and the integrated short guide provides a helping hand.

### Customising

CleanSwitch's visually appealing, straightforward design can be adapted in a whole range of ways to suit customers' preferences. It takes just a few seconds to change the colour, level of brightness and mode of the optical feedback – without tools. Not only that, but Bircher also supplies a wide selection of pictograms that can be printed onto the front of the device to make it even more user-friendly. Customised pictograms and logos can also be applied on request.

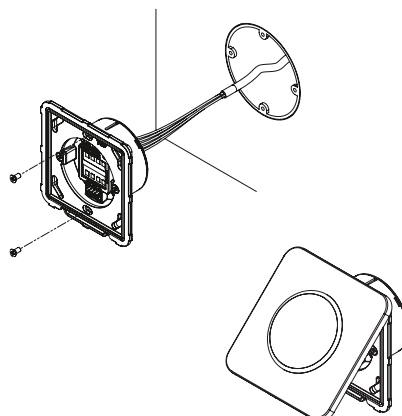



## Reliable in every application

### Situation

Hospitals, clinics, retirement homes

### Solution

- CleanSwitch provides a convenient, contact-free entrance activation method that does away with the need for contact with door handles – which are often contaminated. CleanSwitch can be treated with any standard cleaning agent or disinfectant. The high-contrast LED feedback is easy to identify for people with impaired vision.

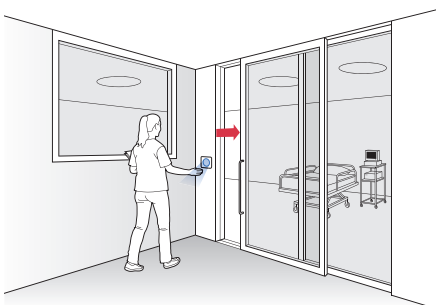

### Situation

Public sanitary areas

### Solution

- CleanSwitch provides a contact-free method of opening automatic doors to public sanitary areas, and prevents the spread of bacteria and other pathogens.

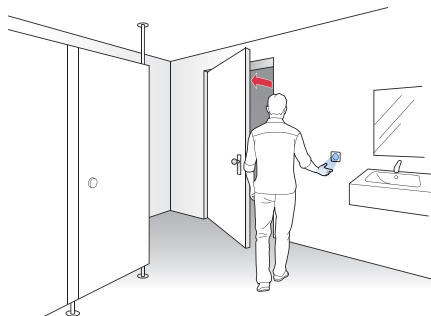

### Situation

Catering industry

### Solution

- CleanSwitch activates the door by means of a gesture. This means that the entrance to the kitchen is only opened when required – providing service staff with a convenient, hygienic door-opening solution.

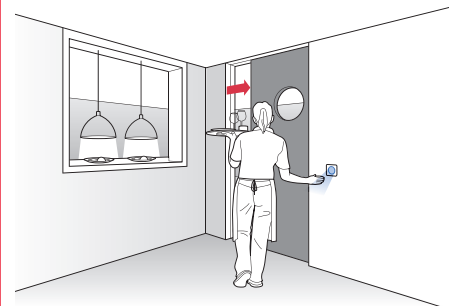

## Technical data

### Mechanical data

|                 |                             |
|-----------------|-----------------------------|
| Material        | ASA / PC                    |
| Dimensions      | 88 × 88 × 38 mm (L × W × D) |
| Weight          | 55 g                        |
| Connection type | Plug terminals              |
| Colour          | White                       |

### Electrical data

|                         |  |
|-------------------------|--|
| Operating voltage       | 12–24 V AC ±10% (50–60 Hz)<br>12–24 V DC +20%/–10%     |
| Frequency range         | 50–60 Hz   |
| Power consumption       | ~ 1 W  |
| Output                  | Potential-free relay with<br>changeover contact        |
| Max. switching voltage  | (DC) 1 A to 30 V, 0.5 A to 60 V<br>(AC) 1 A to 50 V    |
| Max. switching capacity | 30 W (DC) / 50 VA (AC)                                 |
| Output fall-delay time  | Relay fall-delay time 0.3 s<br>LED fall-delay time 2 s |

### Technological data

|                        |  |
|------------------------|--|
| Technology             | Radar  |
| Transmission frequency | 24.125 GHz   |
| Detection range        | 0.1–0.6 m  |
| Detection mode         | – Pulse mode: Detector is triggered by movement of hand<br>– Toggle mode: first movement door open / second movement door closed |
| Detection speed        | Min. 5 Hz or ± 3 cm/s<br>Max. 200 Hz or ± 1.2 m/s  |

### Ambient conditions

|                                 |                               |
|---------------------------------|-------------------------------|
| Protection class                | IP65                          |
| Storage / operation temperature | –20 °C to +60 °C              |
| Air humidity                    | < 95% rel.,<br>non-condensing |

### Electromagnetic compatibility standards

|            |                                   |
|------------|-----------------------------------|
| Directives | RoHS 2011/65/EU<br>RED 2014/53/EU |
| Immision   | EN 61000-6-2                      |
| Emission   | EN 61000-6-3                      |

#### Note

Technical details and recommendations concerning our products are based on experience and are an aid for the orientation of the user. Details stated in our brochures and data sheets do not guarantee special properties of the products. This does not apply to special product properties confirmed by us in writing or individually. Subject to technical alterations.

## Configuration

|                    |   |           |   |               |
|--------------------|---|-----------|---|---------------|
| <b>CleanSwitch</b> | / | <b>wt</b> | / | <b>close1</b> |
|--------------------|---|-----------|---|---------------|

| Device            | Cover         | Pictogram |
|-------------------|---------------|-----------|
| CleanSwitch       | wt = white    | blank     |
| CleanSwitch Basic | bk = black    | close1    |
| CleanSwitch Lock  | no = no cover | ...       |

### Description

|   |  |
|---|--|
| <b>CleanSwitch</b><br>With optical feedback |  |
|---|--|

|  |  |
|--|--|
| <b>CleanSwitch Basic</b><br>Without optical feedback |  |
|--|--|

|                                       |  |
|---------------------------------------|--|
| <b>Pictograms</b><br>Printed on cover |  |
|---------------------------------------|--|

|  |  |
|--|--|
| <b>CleanSwitch Coverless</b><br>Device without cover with optical feedback |  |
|--|--|

|  |  |
|--|--|
| <b>CleanSwitch Basic Coverless</b><br>Device without cover |  |
|--|--|

## Components and accessories

### Description

| Covers<br>Printed | blank  | close1 | open1  | close2 | open2  | close3 |
|-------------------|--------|--------|--------|--------|--------|--------|
| White cover       | 368145 | 364980 | 364981 | 364982 | 364983 | 364984 |
| Black cover       | 371142 | 371113 | 371114 | 371115 | 371116 | 371117 |

|  | open3  | close4 | open4  | hand wave | hand   | wheelchair | lock   |
|--|--------|--------|--------|-----------|--------|------------|--------|
|  | 364985 | 364986 | 364987 | 419281    | 364988 | 364989     | 420507 |
|  | 371118 | 371127 | 371128 | 419284    | 371140 | 371141     | 420509 |

|               |   |  |
|---------------|---|--|
| <b>371199</b> | <b>CleanSwitch surface-mounted box, white</b><br>IP65 |  |
|---------------|---|--|

|               |   |  |
|---------------|---|--|
| <b>371200</b> | <b>CleanSwitch surface-mounted box, black</b><br>IP65 |  |
|---------------|---|--|

|               |   |  |
|---------------|---|--|
| <b>412057</b> | <b>HACCP surface-mounted box, white</b><br>IP65 |  |
|---------------|---|--|

|               |   |  |
|---------------|---|--|
| <b>412056</b> | <b>HACCP surface-mounted box, black</b><br>IP65 |  |
|---------------|---|--|

## BBC Bircher Smart Access

Distribution Partner

**Colterlec**

Phone 1300 36 26 26

sales@colterlec.com.au

www.colterlec.com.au