

## Mechanical Trapped Key Interlocks Certified to PLe

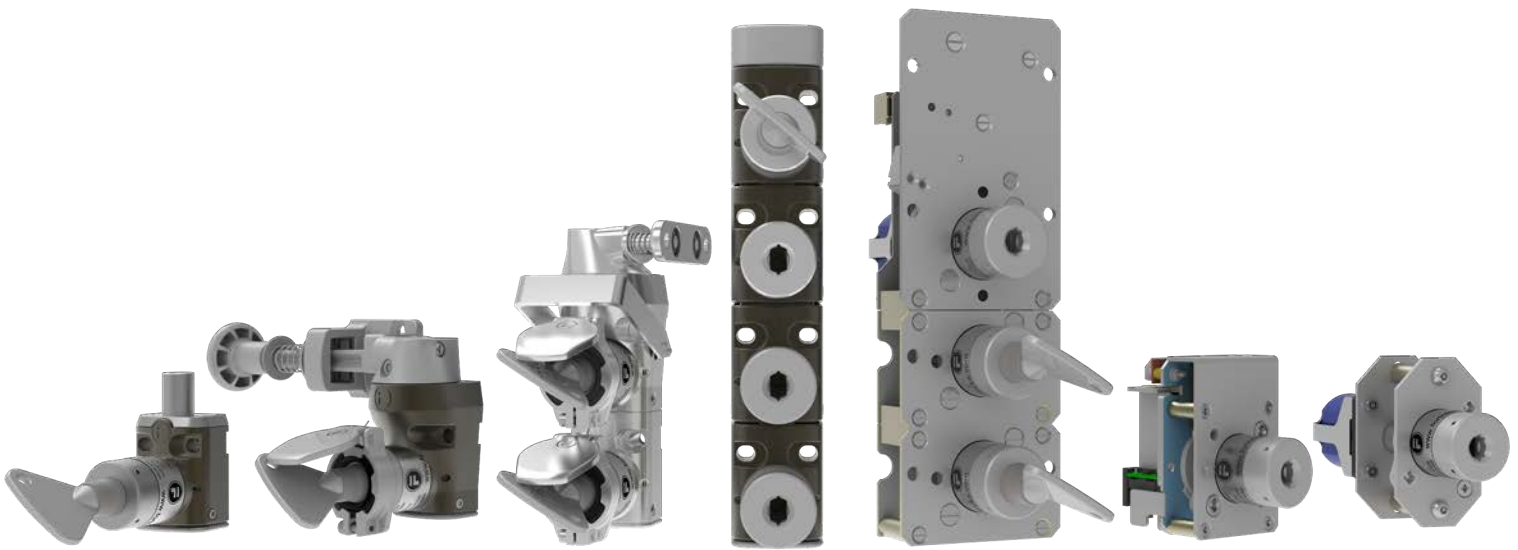

THE QUEEN'S AWARDS  
FOR ENTERPRISE:  
INTERNATIONAL TRADE  
2018



C



US







## Introduction to Fortress:

**Fortress** designs and manufactures customised safety equipment, protecting lives in hazardous workplaces. Our reputation is as a global provider of robust safety specifications for manufacturing environments.

**Why Interlocks?** Interlocking is a method of controlling two or more interdependent operations which must take place in a predetermined sequence, if necessary remotely controlled or time delayed. The need for this sequence may be safety to personnel and equipment, or it may be to control processes and productivity.

Over the last 40 years, Fortress has become well known in the industry for innovative design, robust engineering and reliability. Headquarters are in Wolverhampton (UK), with supporting offices and manufacturing facilities in the USA, Netherlands, Australia and China, further supported by a global network of trusted distributors and channel partners.

## Fortress' current product portfolio includes:

-  **mGard** - The only range of mechanical interlocks independently certified to PLe
-  **amGardpro** - Heavy duty safety gate switches with connectivity and trapped key integration certified to PLe
-  **amGardS40** - Stainless steel IP69K safety gate switches independently certified to PLe
-  **tGard** - Medium duty interlocks with configurable built-in control functionality independently certified to PLd
-  **ncGard** - A range of safety switches with non-contact technology



## Why Interlocks?

Interlocking is a method of controlling two or more interdependent operations which must take place in a predetermined sequence, if necessary remotely controlled or time delayed. The need for this sequence may be safety to personnel and equipment, or it may be to control processes and productivity.

### For Reference-

- ISO 14119 is the interlocking standard that forms part of the machinery directive.
- ISO/TS 19837:2018 is the technical specification relevant to trapped key interlocking.

## Why Mechanical?

- One power isolator can be used for multiple doors through the use of a key exchange unit.
- This reduces any fault masking risks and wiring installation required.
- In addition mechanical interlocking is the only method of safeguarding solutions for multiple energy sources.
- Personnel keys can be used to prevent unexpected start up of machinery as per ISO 14118, removing the necessity for escape functions.

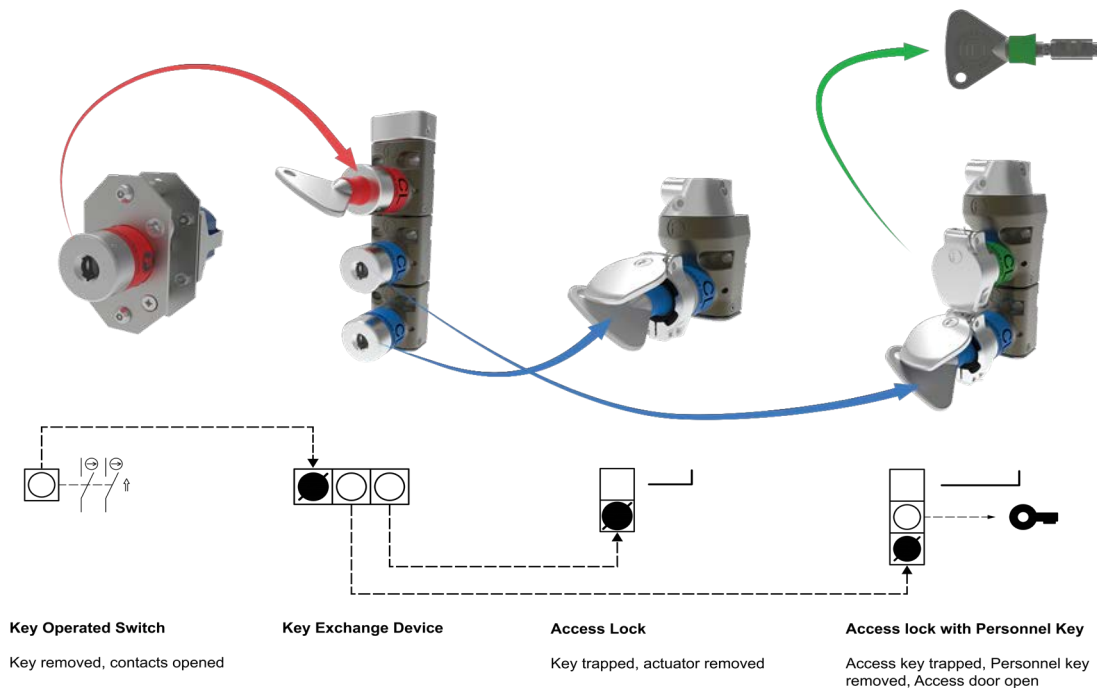

mGard is the only range of trapped key interlocks 3rd party approved as being capable of meeting PLe and is perfect for heavy duty applications. Fortress' mGard is suitable for use up to SIL3 (EN/IEC 62061), Category 4 and PLe (EN/ISO 13849-1).

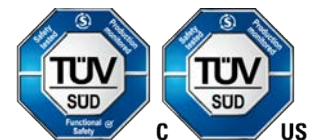

Trapped key interlocking is a tried and tested method of mechanically safeguarding dangerous machines and hazardous processes. Mechanical keys eliminate most of the electrical wiring associated with other types of interlocks making it cost effective to install and maintain.

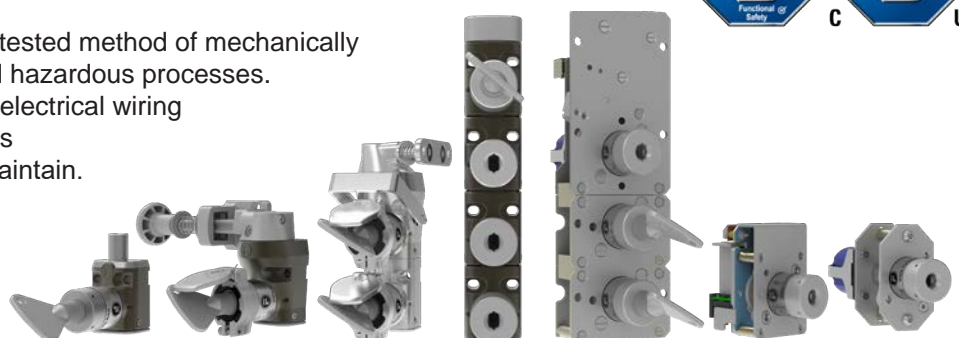

# Robot Welding Cell

## Application Requirement:

This robot welding cell's safety system must only allow operators to enter the cells when power to the cell has been isolated and the machinery has come to a controlled stop after a defined run-down time. After access, the system prevents unexpected start up when multiple operators are performing maintenance, via Personnel Keys.

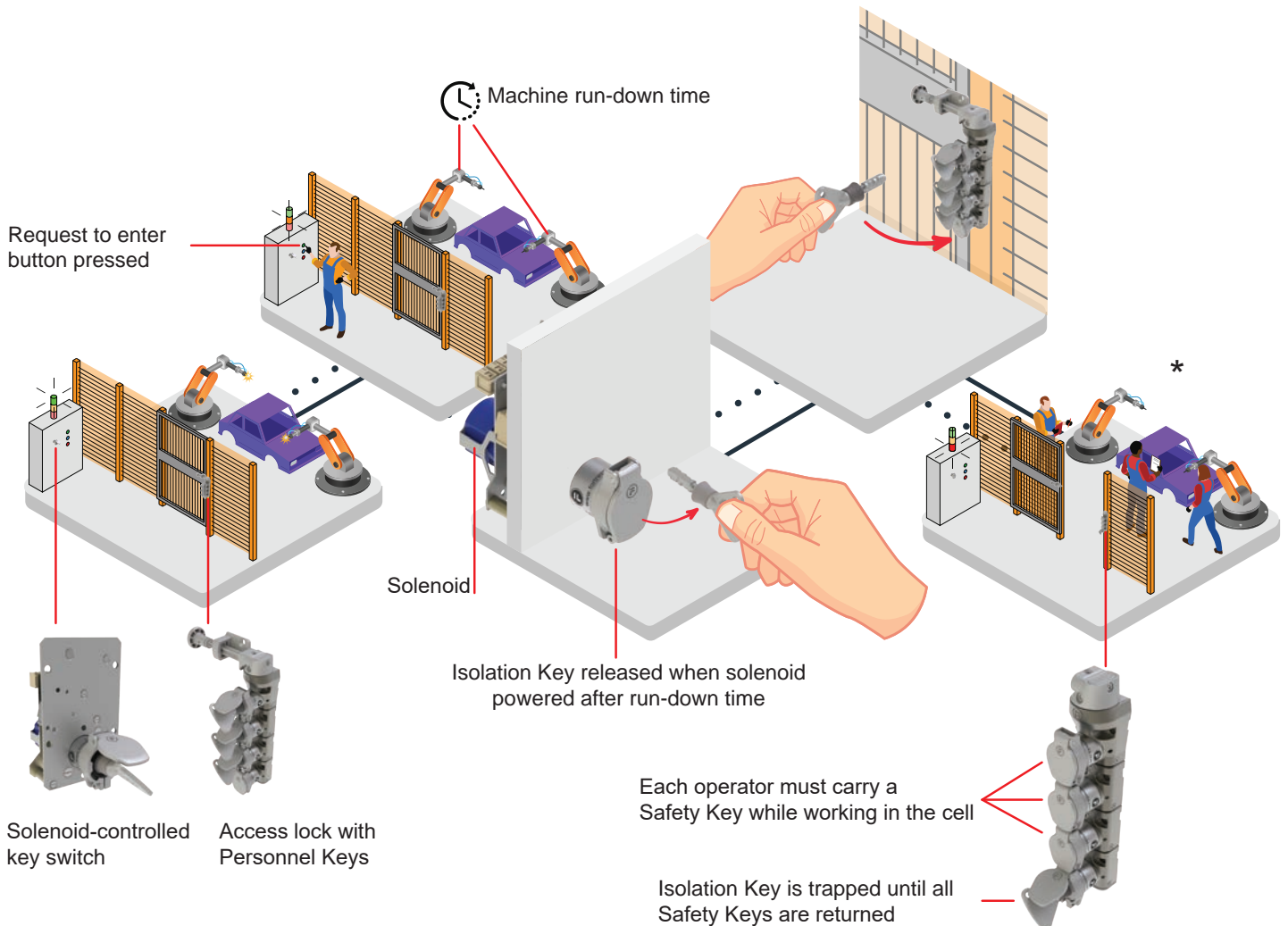
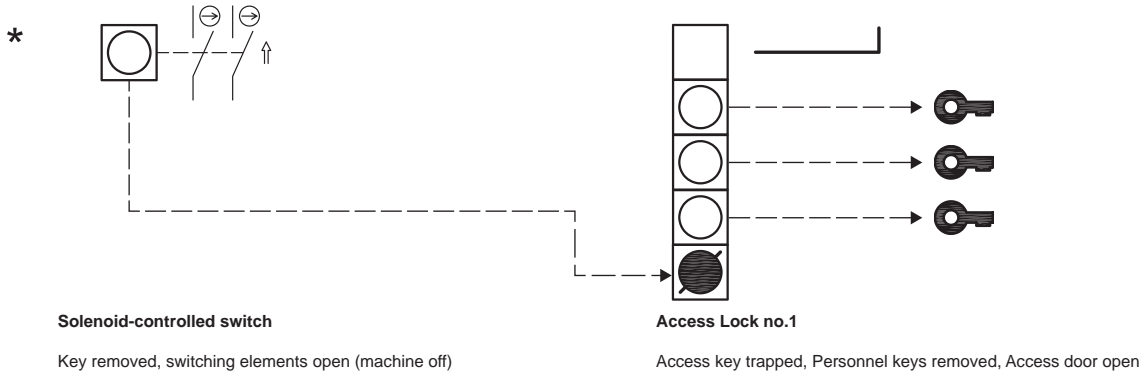

# Concrete Mixer

## Application Requirement:

Industrial concrete mixers have multiple access hatches that are safeguarded by mechanical interlocks. These access hatches are opened for scheduled cleaning under the protection of the installed safety system. Access is only allowed once the power switch to the mixer has been mechanically isolated.

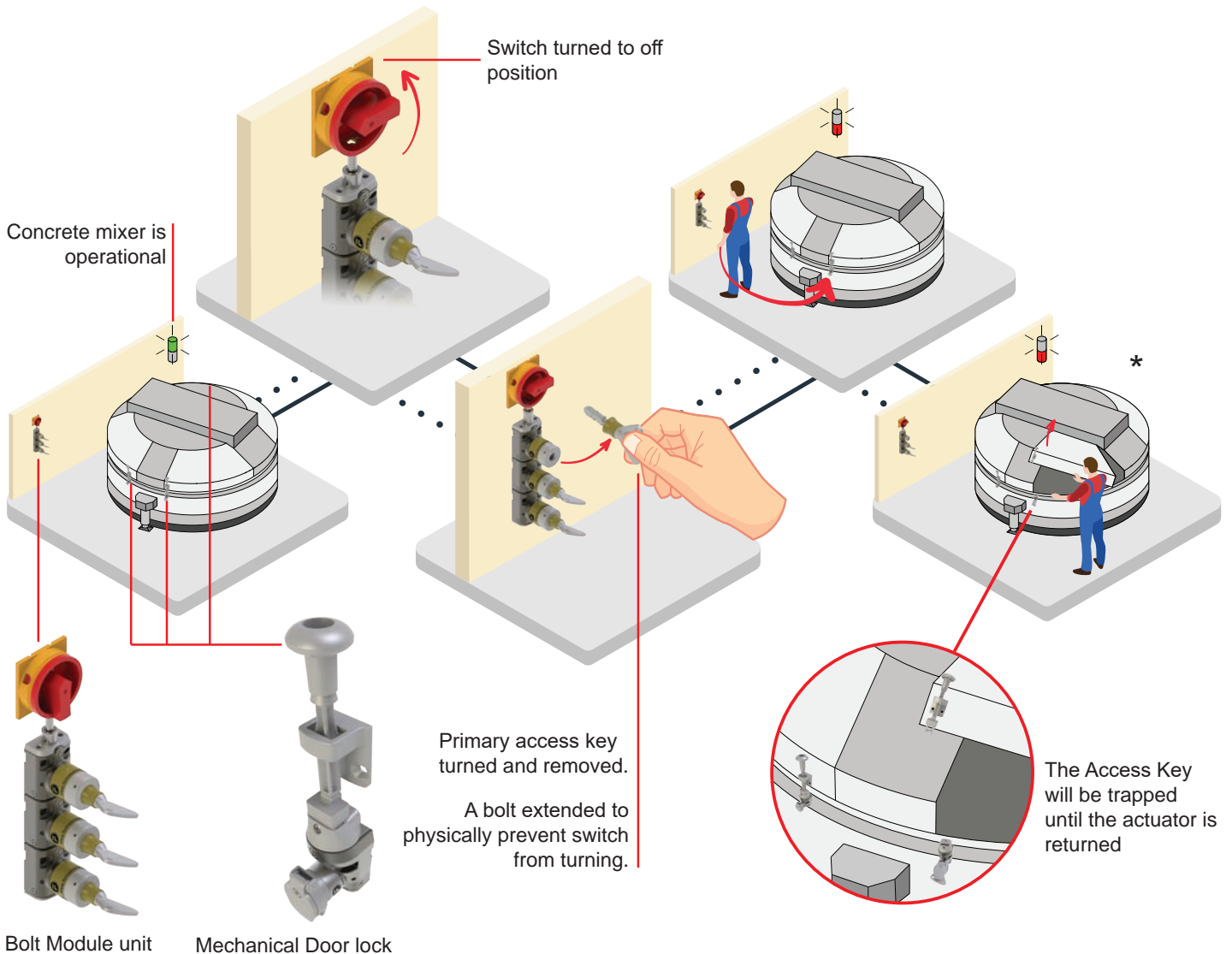
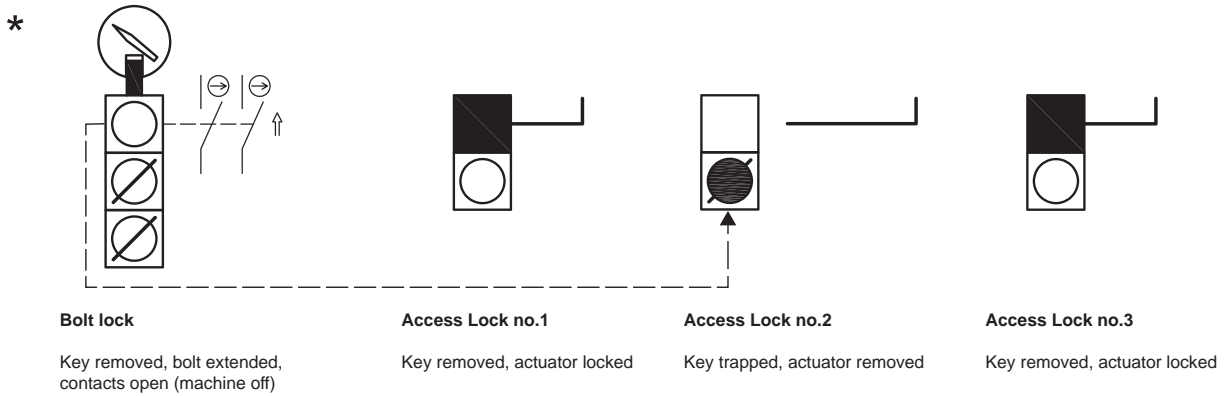

# Double Backer

## Application Requirement:

The double backer machines enclosed in two cells requires extensive safeguarding. A safety system for the cells should ensure operators and maintenance personnel can only enter the areas once power to all of the machinery has been isolated and has come to a controlled stop.

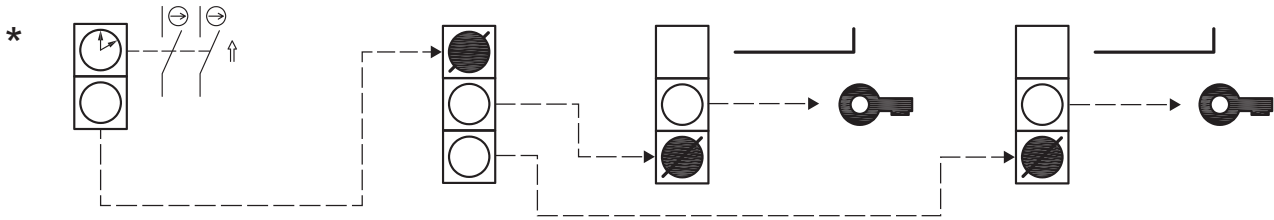

**Time delay device**

Key removed,  
switching elements open (machine off).

**Key exchange device**

Isolation key trapped,  
Access keys removed.

**Access Lock with Personnel key  
no.1**

Access key trapped,  
Personnel key removed,  
Access door open.

**Access Lock with Personnel key  
no.2**

Access key trapped,  
Personnel key removed,  
Access door open.

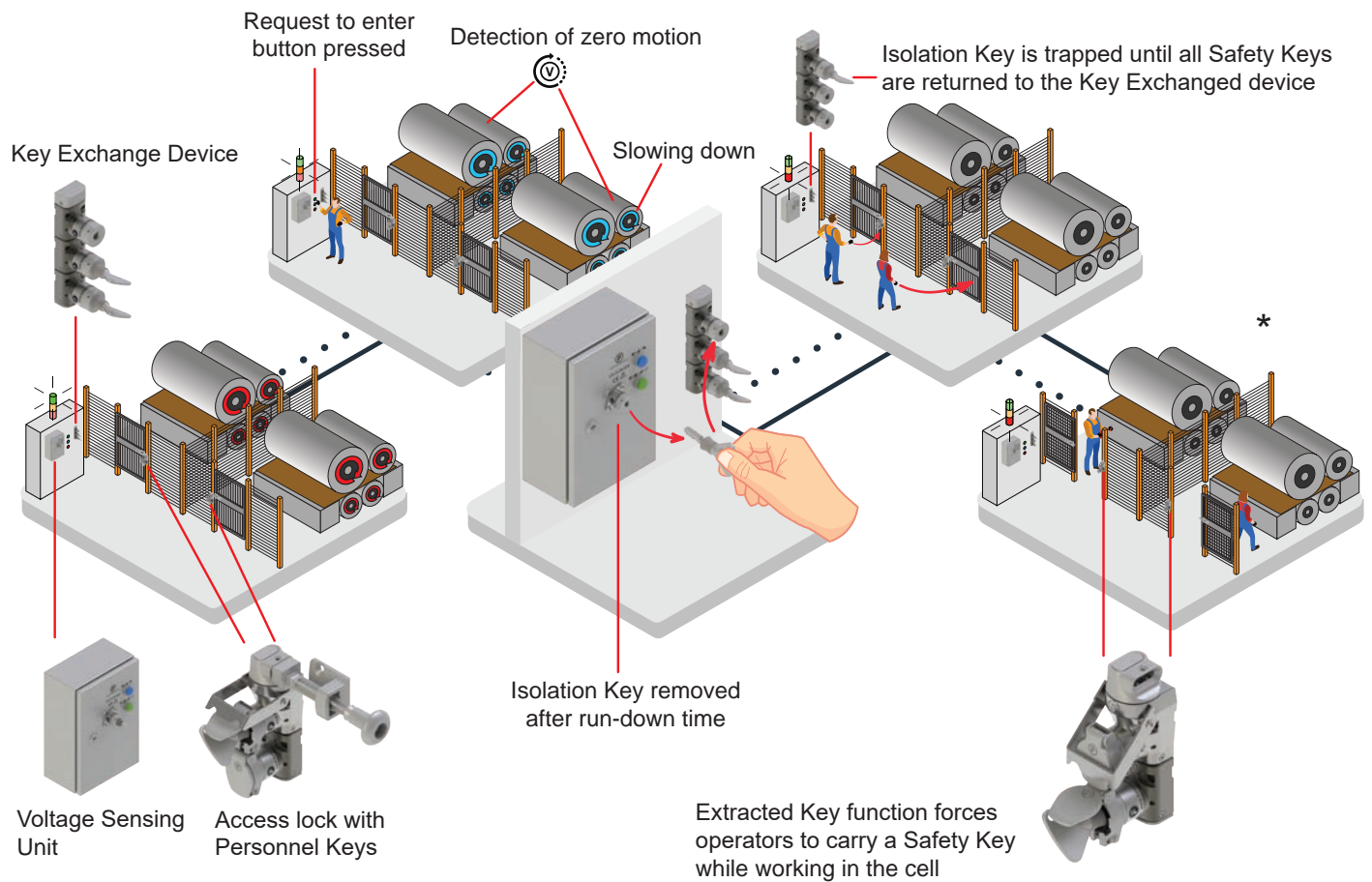

# Valves & Specials

## Valves & Pneumatic Interlocks

Fortress supplies a range of interlocks suitable for valve applications and for pneumatic isolation. With the incorporation of a mechanical module and key to a valve, Fortress has created a simplified solution for controlling the position of the valve and isolating the valve movement without the need of levers or hand-wheels in other forms of valve interlocking/lockout.



### Valve Application 2

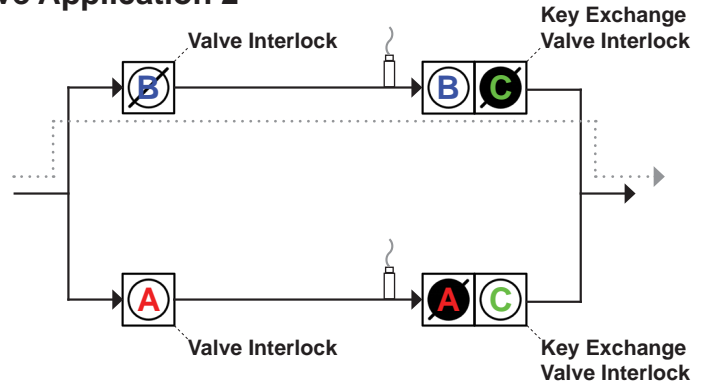

### Valve Application 1

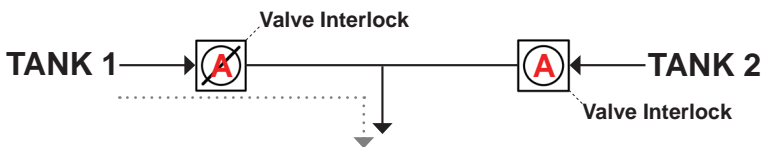

In this application, only one of the tanks can feed into the supply at once. The use of Valve Interlocks insures only one of the lines can be open because the two interlocks share a single key. Each valve can only be opened while a key is trapped to the locked position in the interlock.

In this application, at least one pressure release line must be open at all times. The use of the Valve Interlocks insures at least one line will always be open because the independent interlocks A and B require their corresponding key to be turned to the locked position to close the valve. The two Key Exchange Interlocks share one key for the two locks marked C. The key for the two C locks is transferred between the units to always trap either the A or B key.

## Specials and Custom Units for Applications

Over the years, Fortress has produced many special-purpose units designed to meet the specific needs of its customers and applications within their industries. Some of these units include: standalone time delay/voltage sensing, ATEX rated switches/solenoids and elaborate key sequencing exchange boxes. Some of these units have been added to the mGard range as their popularity in applications has grown throughout the years, but are considered non-standard or specials solutions due to the extended lead time required to design and manufacture.

Fortress has also helped customers create completely custom units that were specific to one individual application. These units were created in collaboration with engineers between both parties to better understand the needs and constraints of the application. Fortress is pleased to offer advice and assist without obligation; although a more simple solution may be proposed through standard mGard units or the other ranges Fortress has to offer.

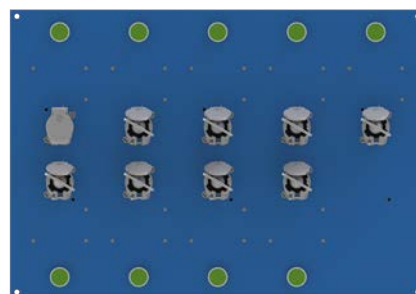

## Power Isolation

### Control Interlocking

Panel Mounted

Panel Mounted Weatherproof

In Enclosure

Key Switch(es)



Mini Solenoid Controlled Key Switch(es)



Solenoid Controlled Key Switch(es)

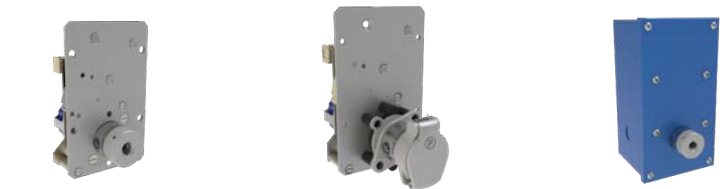

ATEX Solenoid Controlled Key Switch



ATEX Key Switch



Knob Operated Switch Control Unit



Key Operated Switch Control Unit



Electronic Time Delay Unit



Voltage Sensing Unit



### Power Interlocking

Mechanical Bolt Interlock



Bolt Interlock with Limit Switch



Bolt Interlock with Switch



Circuit Breakers



Valve & Pneumatic Interlocks





## Key Exchange

Modular Key Exchange Unit



Modular Key Unit with Switch(es)



## Door Locks

Single Door Interlock



Multiple Modular Door Interlock



Forced Safety Key Door Interlock



All in One Door Interlocks



## Actuators

Fixed Actuator



Handle Operated Actuator



Spring Released Handle Operated Actuator



Compressible Actuator



Self Aligning Actuator



## Keys & Locks

Standard



Masterable



Colours available for key seal and lock label.

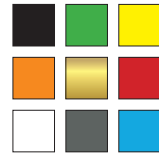

Colours available for key bow and dustcovers.



3 lines of 10 characters available for engravings.

Low Profile



## Accessories

Extension Module

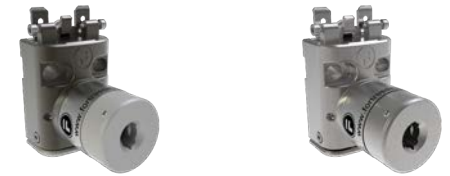

Dustcovers (Available as Standard & Padlockable)



Lockout Hasps (For 3x Padlocks)



Back of Board Mounting Kit



**BM1 Unit**



**XMA Unit**



**m**  
Additional Modules Fitted when multiple locks are selected

**BMR1 Unit**



**m**  
For BML2 switch is 2NC 1NO positive break

**BML2 Unit**

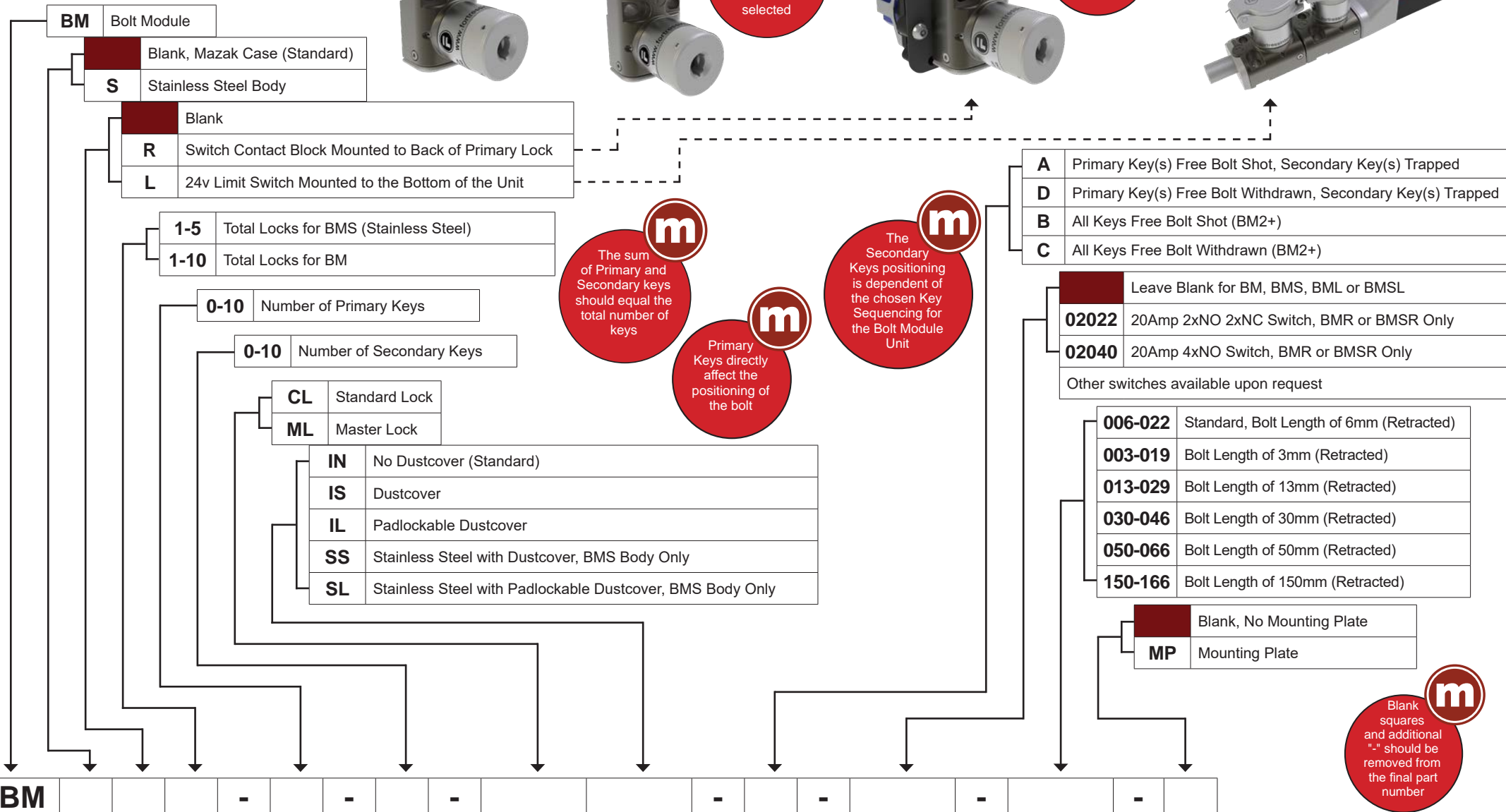

S Unit

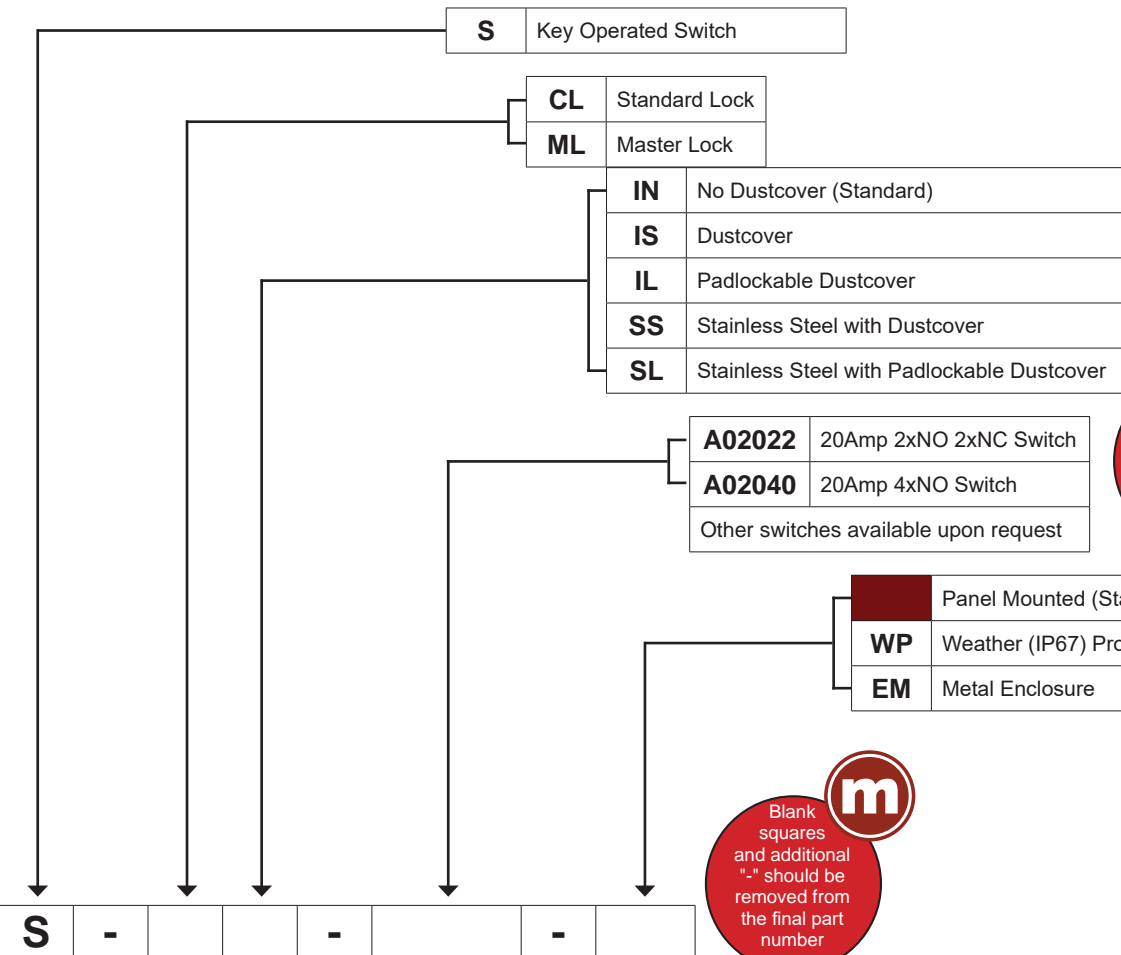

S-WP Unit



The lock on a S-WP must be comprised of either SS or SL

S-EM Unit



The lock used in the switch determines the enclosure. IN, IS and IL for Zinc Alloy or Mild Steel. SS and SL for Stainless Steel



Larger switches will be in a larger enclosure



Blank squares and additional "-" should be removed from the final part number

SS1-B



Add-on lock modules are fitted to the solenoid if multiple keys are released by the solenoid

SS1-WP



SS1-F



The sum of Primary and Secondary keys should equal the total number of keys

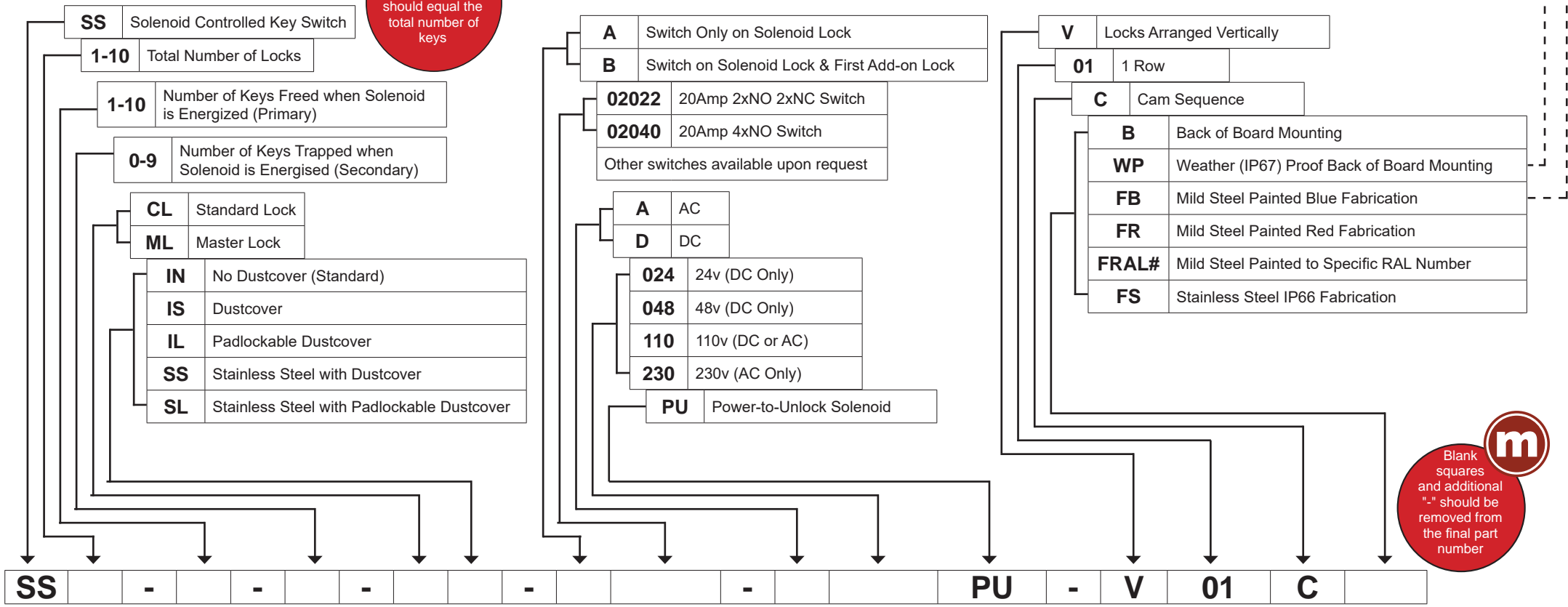

SS - - - - - PU - V 01 C

MSS Unit



MSS-EM Unit



MSS-WP Unit



**m**  
The contact block in the Mini Solenoid Controlled Key Switch are only available as a 3Amp 2xNC Switch

**m**  
The Solenoid used in the Mini Solenoid Controlled Key Switch are all Power-to-Unlock

**m**  
MSS-WP Panel thickness must be 1.5 - 3.5 mm

**m**  
Blank squares and additional "." should be removed from the final part number

<b>MSS</b>	Solenoid Controlled Key Switch
<b>1</b>	One Key Freed when Solenoid is Energized
<b>0</b>	Zero Keys Trapped when Solenoid is Energized
<b>CL</b>	Standard Lock
<b>ML</b>	Master Lock
<b>IN</b>	No Dustcover (Standard)
<b>IS</b>	Dustcover
<b>IL</b>	Padlockable Dustcover
<b>SS</b>	Stainless Steel with Dustcover
<b>SL</b>	Stainless Steel with Padlockable Dustcover

<b>A00302</b>	3Amp 2xNC Switch
<b>A</b>	AC
<b>D</b>	DC
<b>024</b>	24v (DC Only)
<b>048</b>	48v (DC Only)
<b>110</b>	110v (DC or AC)
<b>230</b>	230v (AC Only)

<b>PU</b>	Power-to-Unlock Solenoid
	Panel Mounted (Standard)
<b>WP</b>	Weather (IP67) Proof Back of Board Mounting
<b>EM</b>	Metal Enclosure (Option Pod), 24v DC Solenoid Only

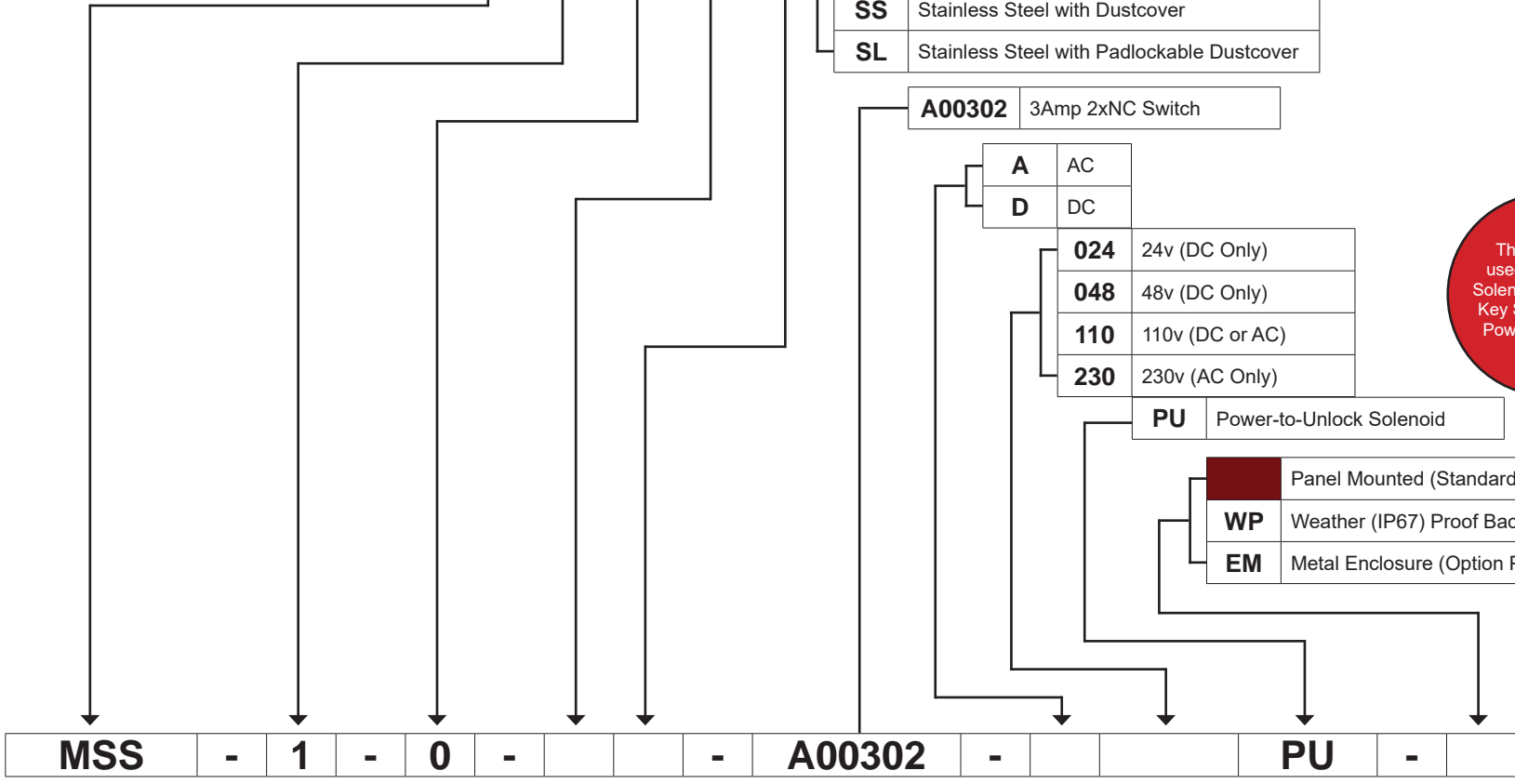

**MSS** - **1** - **0** - - - **A00302** - - - **PU** - -

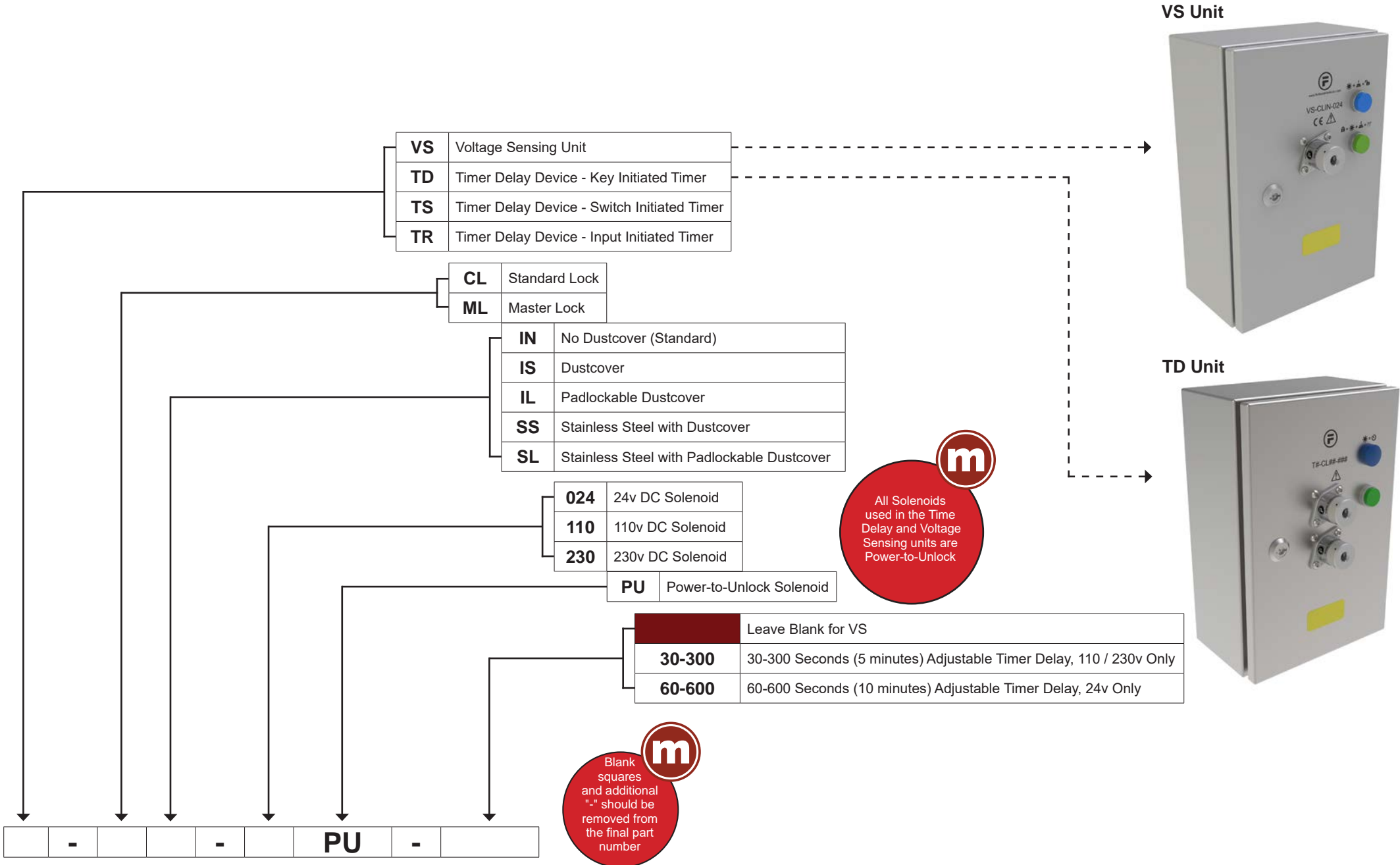

SCU1-B Unit

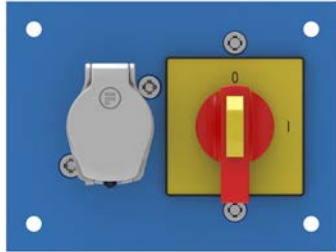

LCU4-B Unit

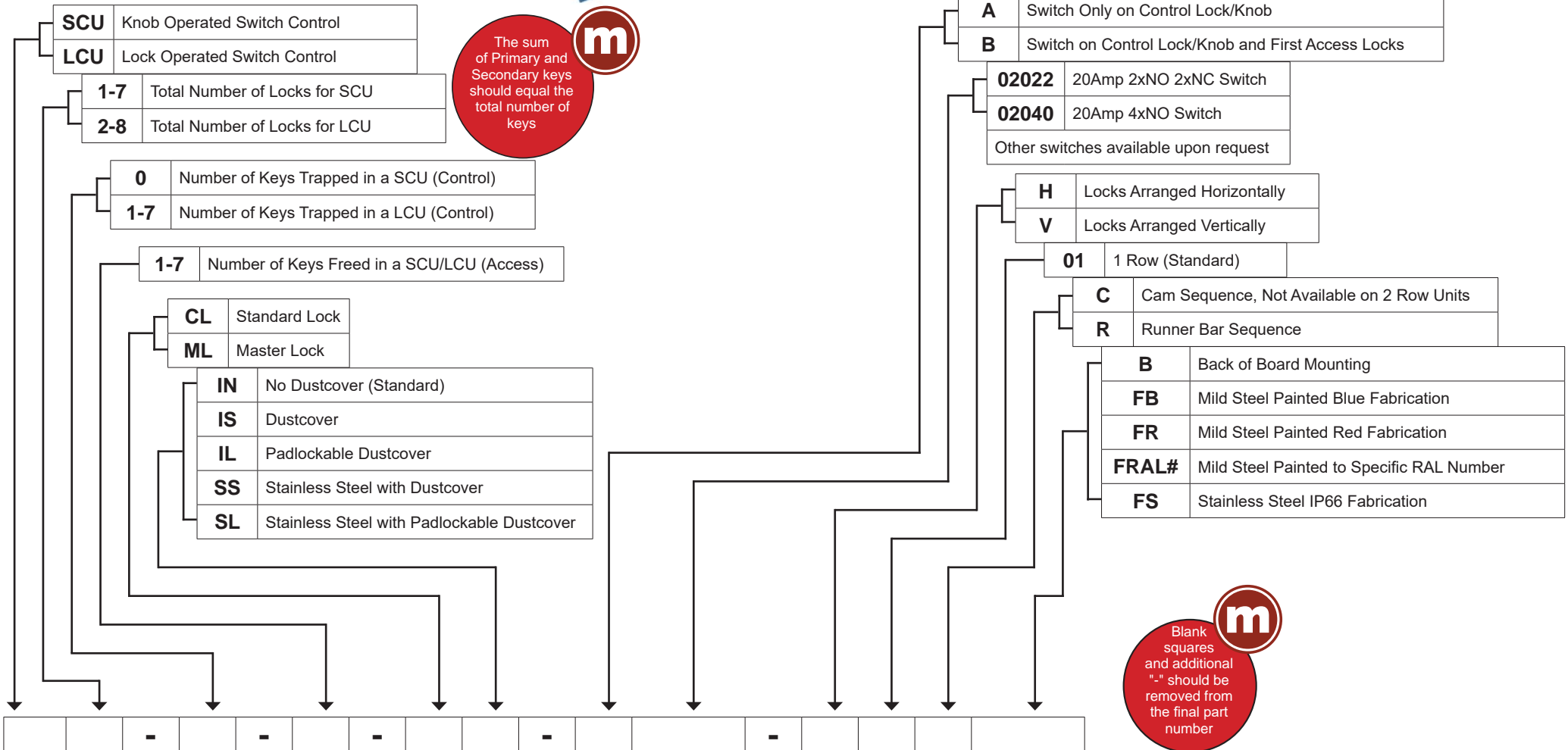

The sum of Primary and Secondary keys should equal the total number of keys

**XM2 Unit**



**XMR2 Unit**



**XML2 Unit**

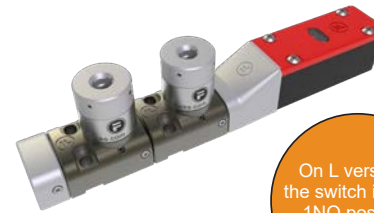

**XMA Unit**



**m**  
On L versions  
the switch is 2NC  
1NO positive  
break

**m**  
Additional  
Modules Fitted  
when multiple  
locks are  
selected

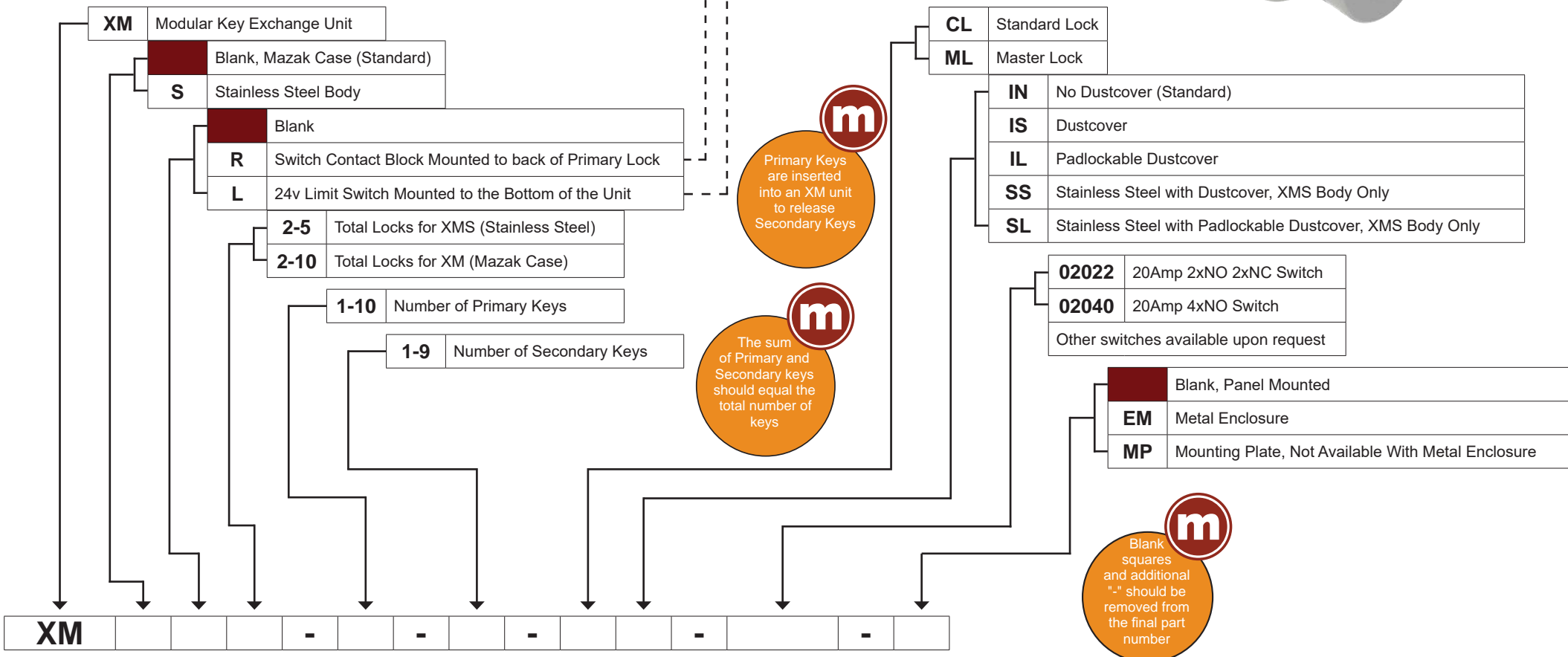



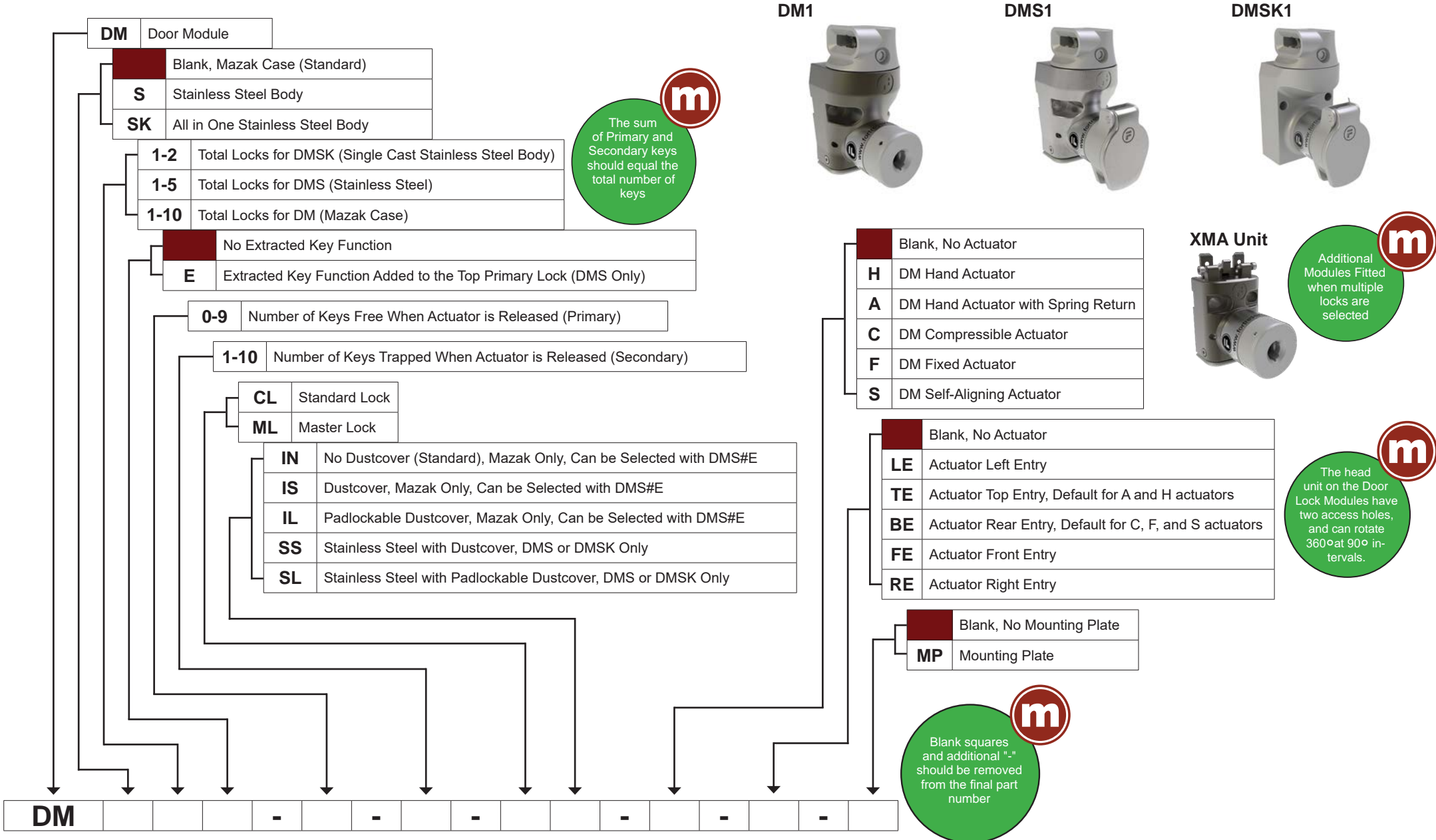

# Keys and Accessories

<b>CLK</b>	Standard Key
<b>MLK</b>	Masterable Key

<b>SU</b>	Uni Directional
-----------	-----------------

<b>N</b>	No Seal (Low Profile Keys Only)
<b>S</b>	Silver Seal, (CLK Standard)
<b>G</b>	Gold Seal, (MLK Standard)
<b>C</b>	Coloured Seal and/or Bow

<b>S</b>	Standard Cut
<b>M</b>	Master Cut, Masterable Key Only (MLK)

	Standard Colour Seal / No Seal
<b>V</b>	Viton (Black) Seal, (Only if C is Selected)
<b>L</b>	Green Seal, (Only if C is Selected)
<b>Y</b>	Yellow Seal, (Only if C is Selected)
<b>O</b>	Orange Seal, (Only if C is Selected)
<b>R</b>	Red Seal, (Only if C is Selected)
<b>W</b>	White Seal, (Only if C is Selected)
<b>B</b>	Blue Seal, (Only if C is Selected)

	Blank, No Colour for Bow (Standard)
<b>VB</b>	Black Bow, (Only if C is Selected)
<b>GB</b>	Green Bow, (Only if C is Selected)
<b>YB</b>	Yellow Bow, (Only if C is Selected)
<b>OB</b>	Orange Bow, (Only if C is Selected)
<b>RB</b>	Red Bow, (Only if C is Selected)
<b>WB</b>	White Bow, (Only if C is Selected)
<b>BB</b>	Blue Bow, (Only if C is Selected)
<b>LP</b>	Low Profile Bow, Only if N (No Seal) is selected



**CLK-SUSS**



**MLK-SUGS**



**MLK-SUCS-VYB**



**CLK-SUNS-LP**

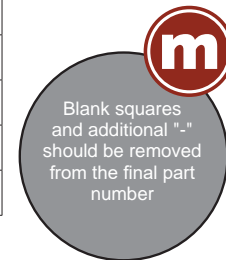

Blank squares and additional "-" should be removed from the final part number

# Keys and Accessories

Stainless Steel Dust Cover



Part Number

**CLDC**

Stainless Steel Padlockable Dust Cover



Part Number

**PLDC**

Lockout Scissor Hasp



Part Number

**LOS3**

Lockout Scissor Hasp with Cable



Part Number

**LOS3C**

Back of Board Adaptor



Part Number

**M-BOB**

Add-On Lock Module



Part Number

**XMA-CLIN:** Mazak Body, No Dustcover

**XMA-CLIS:** Mazak Body, Dustcover

**XMA-CLIL:** Mazak Body, Padlockable Dustcover

Stainless Steel Add-On Lock Module



Part Number

**XMSA-CLSS:** Stainless Steel Body, Dustcover

**XMSA-CLSL:** Stainless Steel Body, Padlockable Dustcover

# Mechanical Trapped Key Interlocks Certified to PLe

A **Halma** company

